

INSTRUCTION MANUAL

BS-75A Belt Linisher Sander (415V) 75mm x 2000mm Belt Size



L122

L122 BS-75 LINISHER

4/7/05

OPERATION MANUAL FOR

Belt Grinders **Model S-75 / 150**



Technical data:

		S-75	S-150
Motor	kW	3,00 / 4,00	3,00 / 4,00
Contact Wheel	mm	200 x 75	200x 150
Steering Roller	mm	225 x 75	225 x 150
Flat Grinding	mm	530	530
Belt Size	mm	2000 x 75	2000 x 150
Belt speed	mm/sec.	34	34
Working height	mm	475-1240	475-1240
Weight	kg	85	105
W x H x L	mm	500 x 1010 x 1000	560 x 1010 x 1000

Installation:

The machine is delivered in a wooden case. The machine should be placed on a level surface and secured by bolts through the four base plate holes.

Check the following functions:

- A) The Belt moves freely.
- B) The Belt does not touch the grinding supports.

Connection to electricity supply:

The S beltgrinder has to be wired in by a competent electrician. The 3,0 kW motor is supplied with an Overload Protection Switch and no-voltage release for direct connection to 3 x 400/415 V or 3 x 230 V, 50/60 Hz. The connection is only to be done with a 4-core cable (1,5 mm²) short cable with plug, making a total electric interruption possible. Fuse 16A (Please see enclosed electrical data sheet).

Belt tracking:

When first starting the machine, the Belt may not run centrally on the Contact Wheel.

This is corrected by turning the tracking Adjuster (6):

- Clockwise - Belt moves towards the left.
- Anticlockwise - Belt moves towards the right.

Changing the belt:

- a) Switch off the machine.
- b) Ensure the Belt is at a complete standstill.
- c) Remove the Spark Trap (1)
- d) Open the Side Cover (12) by turning the handle.
- e) Slacken the Belt by moving the Belt Tension Release Lever (7) downwards.
- f) Replace the Belt. Note correct direction of rotation of the belt.
- g) Tighten the Belt by moving the Belt Tension Release Lever (7) upwards.
- h) Close Side Cover (12) and re-mount Spark Trap (1).

Operation of Belt Grinder:

Eye protection and earplug are to be worn at all times.

Contact Grinding:

When grinding against the Contact Wheel (3), ensure that the Belt Guard (5) is closed. The operator faces the Contact Wheel (3) and holds the material to work up, with both hands. Hands must be placed away from the place to be grinded, as the material will be warm during the operation. The material is pushed against the Belt, resting on the grinding support (2), if necessary. The material is turned and grinded on the required surfaces.

Surface Grinding:

The operator faces the open belt guard (5) during surface grinding. The material is held with both hands and is pushed hard against the top work support (4) the grinding foundation under the belt has to be clean.

Height adjustment:

Loosening clamp no. 9 with an Allen key can do height- and angle adjustment.

Routine maintenance:

Frequent cleaning, if necessary with compressed air so that wheel swarf is removed. Normal maintenance of the contact wheel and the steering roller. A commendable surface grinding can only be obtained when using a completely clean grinding foundation. Otherwise this must be renewed. The belt must be replaced as required, compare "Changing the belt". Spark trap must be emptied frequently.

Special accessories:

Exhaust with dust bag (Electric connection to the overload protection switch (8)).

Position number:

- | | |
|-----------------------|----------------------------------------|
| 1. Spark trap | 7. Belt tension release lever |
| 2. Front work support | 8. Overload protection switch |
| 3. Contact wheel | 9. Clamp for angle & height adjustment |
| 4. Top work support | 10. Steering roller |
| 5. Belt guard | 11. Flange for motorised exhaust |
| 6. Tracking adjuster | 12. Side cover |

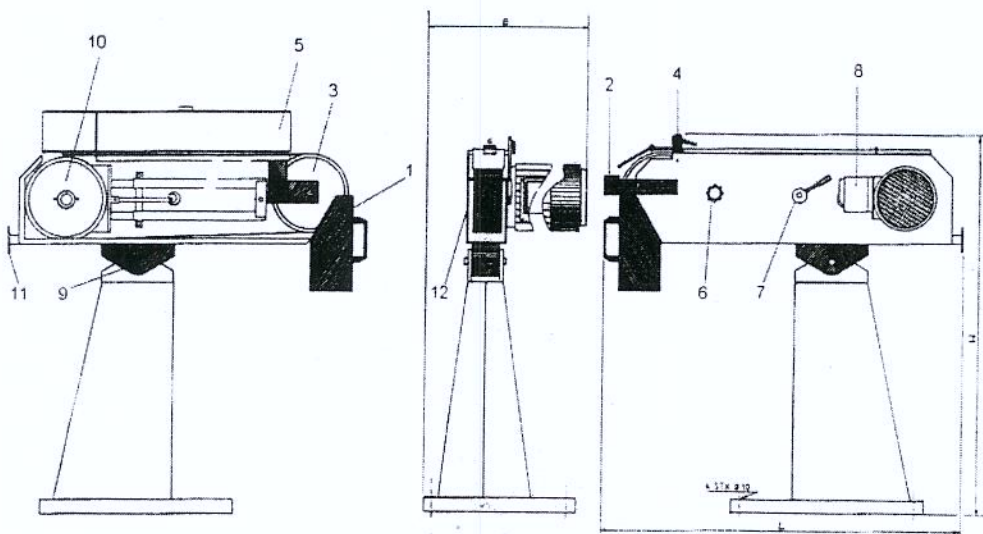

Noise level measurement for Belt Grinders:

RESULT S-75

Sound power of the machine:

A: No load (idle) with exhaustion

B: When grinding flat bar 50 x 15 with exhaustion

Hz	63	125	250	500	1K	2k	4k	A-Distance
A LWa	73	76	91	82	85	88	88	93
B LWa	70	74	86	81	84	88	91	93

Noise level on the place of operation:

A: **85 dB (A)** no loaded (idied) with exhaustion

B: **88 dB (A)** loaded with exhaustion

RESULT S-150

Noise level of the machine when grinding flat bar 50 x 15.

Hz	63	125	250	500	1K	2k	4k	A-Distance
LWa	73	74	80	84	86	89	90	96

Noise level on the place of operation: **90 dB (A)**

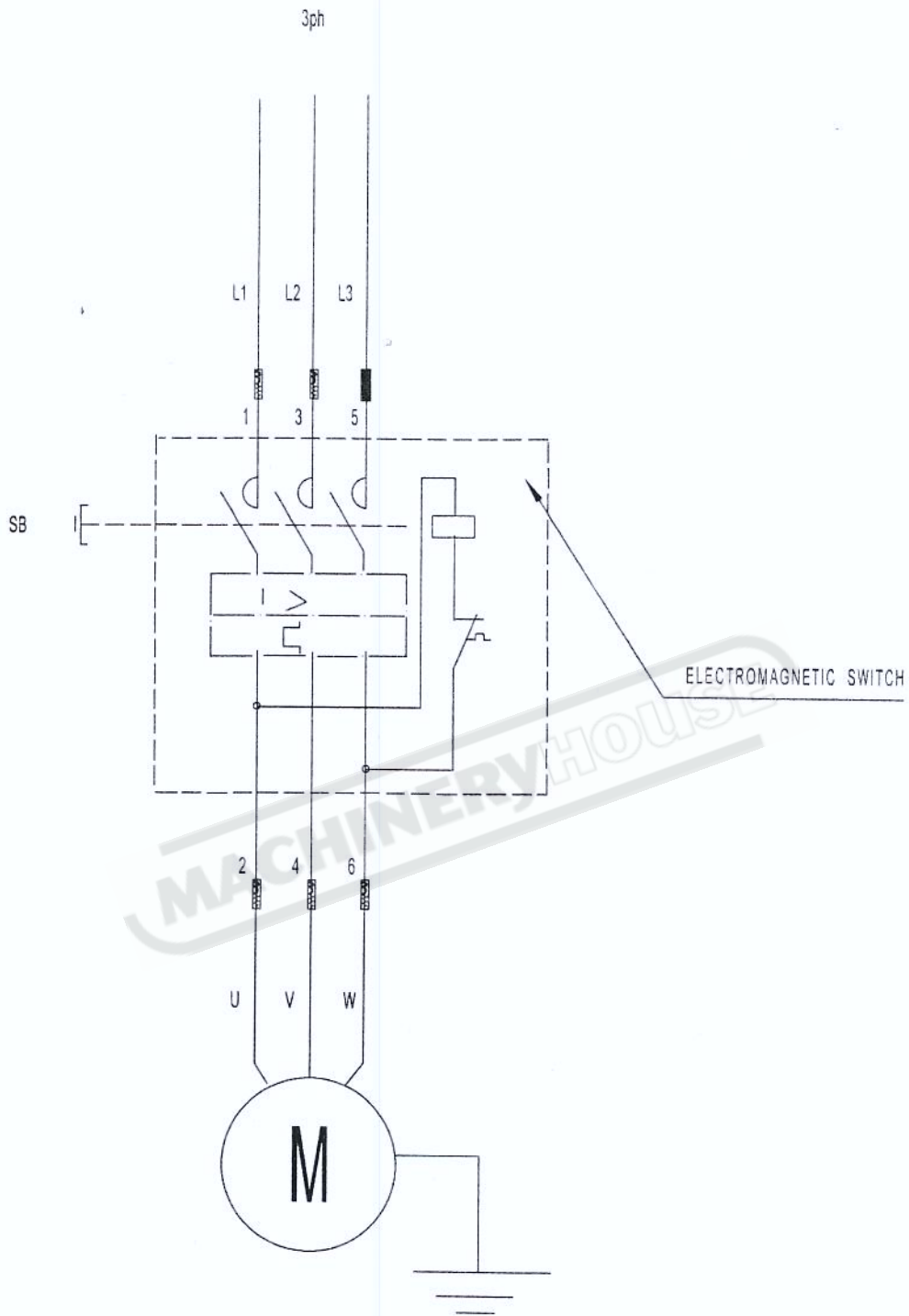

6		S-75/150	Drawn
5			Checked
4			
3		Circuit diagram	Diagram No.
2			
1			

Parts List (S-75)

Part #	Description	Q'ty	Part #	Description	Q'ty
1	Stand	1	37	Eye Protector	1
2	Hex. Screw M12x30	2	38	Nut M4	2
3	Washer	2	39	Block With Thread	1
4	Paper Spacer	2	40	Contact Wheel	1
5	Clamp for angle & height adjustment	2	41	Hex. Screw M10x15	2
6	Nut M10	4	42	Washer	2
7	Washer	4	43	Work Support	1
8	Washer	4	44	Screw M5x16	1
9	Hex. Screw M10x20	4	45	Stop Ring	2
10	Hex. Screw M5x10	2	46	Bearing	2
11	Washer	2	47	Shaft	1
12	Hex. Screw M12x50	2	48	Spacer	2
13	Body	1	49	Motor Support	1
14	Motor	1	50	Nut	1
15	Washer	1	51	Butterfly Spring	1
16	Belt Tension Release Base	1	52	Screw Bar	1
17	Inner Hex. Screw M8x20	1	53	Washer	2
18	Belt Tension Release Lever	1	54	Base	1
19	Sleeve	1	55	Screw M6x25	2
20	Shaft	1	56	Shaft	1
21	Belt Guard	1	57	Elasticity Pin	1
22	Tracking Adjust Knob	1	58	Eccentric Wheel	1
23	Washer	1	59	Washer	4
24	Graphite Layer	1	60	Bolt M8x22	4
25	Nut	2	61	Spring	2
26	Hex. Screw M10x15	3	62	Spring	2
27	Washer	2	63	Elasticity Pin	2
28	Top Work Support	1	64	Pin Shaft	1
29	Top Work Support Plate	1	65	Stop Ring	3
30	Lock Handle	1	66	Draw Bar	1
31	Washer	1	67	Butterfly Spring	12
32	Eye Protector Base	1	68	Support	1
33	Screw M5x8	2	69	Belt Adjustment Device	
34	Hex. Screw M5x50	1	70	Screw	1
35	Screw M4x12	2	71	Protect Buckle	1
36	Eye Protector Binder	1	72	Butterfly Spring	2

Part #	Description	Q'ty	Part #	Description	Q'ty
73	Screw M8x20	1	79	Spark Trap	1
74	Washer	1	80	Bolt M8x15	1
75	Side Cover	1	81	Washer	1
76	Bolt M10x30	1	82	Knob	1
77	Washer	1	83	Overload Protection Switch (Only available for CE)	1
78	Steering Wheel	1			

MACHINERYHOUSE

